

## Maintenance Instructions - Dry Air Coolers & Air Cooled Condensers



### Safety

1. The user is responsible for protection against over pressurisation including that caused by fire.
2. Avoid disconnection whilst unit is under pressure.
3. The equipment is designed for use in a secure area with access limited to authorised personnel.
4. For dry air coolers it is the responsibility of the user to ensure that the fluid is suitable for the operational temperatures and that coil is protected from damage due to freezing.

### Pressure Testing:

All equipment has been tested to 1.43 x the maximum operating pressure (MOP) using Coolers & Condensers Ltd test procedure 6-006. The information about the MOP can be found on the unit label. The equipment must not be subjected to pressures greater than 1.43 x MOP during testing of the system. If a higher system pressure test is required the unit must be isolated from the system to prevent damage.

The MOP is taken as the condensing pressure of the refrigerant at 55°C.

### Lifting & Location

All units are provided with lift channels. These are designed for use with forklifts but can also be used at the outer edge of the unit as a stop locator. The side panels

are provided with hank bushes so the lift channels can be moved from a central position to the outer edges.

Once in position it is important to ensure that all the legs are touching the ground and they support an even load. Failure to do this will result in the casing twisting, causing leaks in the coil tube.

### **Pre-Commissioning**

The use of Plasticol (pre-painted galvanised steel) for the fan housings and bright galvanised steel elsewhere reduces maintenance to a check on accidental damage and certain parts important to the continuing correct function of the condenser. The unit is intended for outside operation in all weathers, however it is helpful to appreciate that all parts benefit from the heat generated by the operation of the coil and fans. For this reason, if there is to be appreciable delay in commissioning, we recommend that some attempt be made to protect the unit in order that it may start its working life in the best possible condition.

### **Condenser Casing**

Check for accidental damage. For the plasticol we can supply small quantities of matching grey touch-up paint; in the event of significant damage to the galvanised steel touch up with zinc rich primer. Depending on local conditions and personal preference the appearance of the unit may be restored by washing - a mild detergent only is advised. This apart no maintenance is required.

### **Coil**

The coil is delivered with a 2 Barg holding charge. This can be verified by accessing the schrader valve on the end of the connection stub. When the unit is delivered the internal pressure should be checked to ensure there are no leaks. If no pressure can be found then a comment should be made on the delivery note.

Whilst in operation the surfaces of the headers can become hot, ensure no unauthorised access by the general public to prevent injury.

Check for any signs of fin deterioration due to atmosphere pollution or clogging by dirt or grease - we suggest 3 or 6 months periods at first. Fin/Coil blocks may be cleaned by hose, mild detergent solution or steam, DO NOT hose directly onto the fan motors and take care not to damage the fins or tubes. It is strongly advised that the coil is thoroughly washed down with fresh water after cleaning to remove any cleaning fluid residue. The coil surface should be returned to as close to pH7. The most effective cleaning technique is to wash the dirt out of the coil in the opposite direction to the normal air-flow. Most of the dirt that fouls a coil accumulates on the air on side and it is not advised to wash this right through the coil as this could make the fouling worse. With finned coil block the maximum washing pressure should not exceed 5 barg.

The most serious problem which may occur is electrolytic corrosion of an aluminium/copper fin block due to sulphurous or saline atmosphere. Fortunately this is rare but it develops as a swelling of the fins, which ultimately block the airways and finally disintegrate. Early identification can allow regular cleaning to remove the sulphate or chloride deposits and extend the life of the condenser, or perhaps to identify and remove the cause of the pollution (it may be nearby exhaust flue). In extreme cases we can supply a replacement copper/copper (or electroplated) coil block complete with headers and casing; we can quote also for site work exclusive of pipe connection.

### Connecting Pipework

It is essential that the discharge and liquid are properly supported and DO NOT rely on the coil headers for support; we recommend the fitting of discharge line vibration isolators. Any vibration in the connecting pipe work can result in leaks on the coil.

Check every 6 months that there is no line vibration and that there is no movement in the support brackets. The connection stubs are not capable of supporting any load; they should not be used as a ladder for accessing the top of the unit.

It is most important that the outlets of condensers are able to drain freely (Ref.: ASHRAE Handbook Refrigeration: System Practices for Ammonia & System Practices for Halocarbon Refrigerants).

On "V" bank units and horizontal air flow coils the condensate falling to the bottom of the outlet header should be able to allow gas to pass back into the header (sewer flow) to allow equalisation between the two commonly connected coil banks. If for any reason the pipe work cannot allow gas to flow freely from one coil to another equalisation lines should be used.

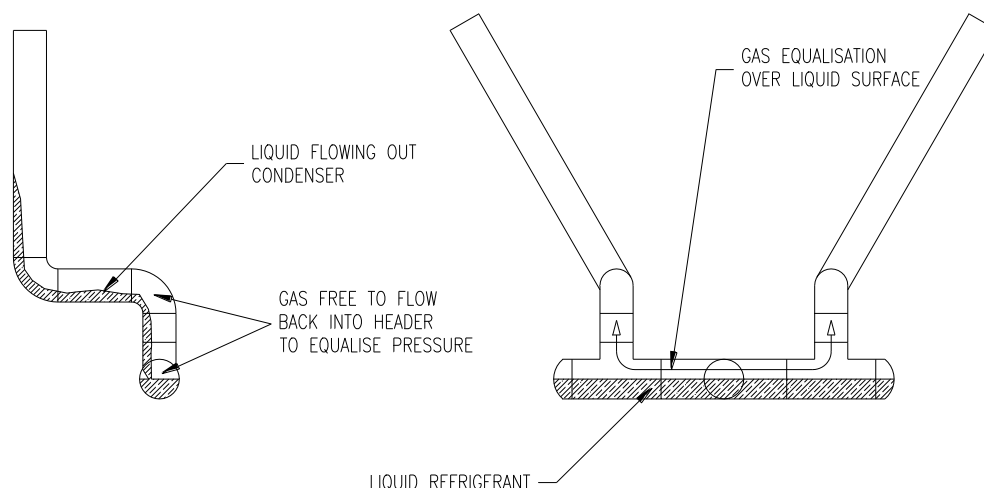

When piping up to a twin coil condenser it is most important to observe the above principal. A lack of good drainage will cause liquid to back up in the condenser coil giving substantial reduction in capacity.

### **Fan Guards**

Should require no attention other than checking they are secure. They are removed for fan access by undoing four bolts and two small centre clips.

### **Fan & Motors**

Motors are fitted with a drain hole in each end cover, and in the terminal box. The motor drain hole should be at the lowest point of the motor when it is installed. Plugs that cover the drain holes should be either removed entirely if condensation is liable to occur due to large variations in operating temperature, or removed periodically to allow any general build up of condensation to drain away. The frequency of plug removal will be dictated by environmental conditions, a record should thus be kept.

Fan motors have bearings sealed for life and should require no attention other than checking that the supply cable is properly secure and that there is no undue noise or rise in motor current. If the unit is left for some while between installation and commissioning it is advisable to run the fan periodically to keep the motor windings free of condensation and to keep the grease spread evenly within the bearings.

Impellers should be examined for any sign of corrosion, particularly on leading edges and touched up if necessary. The securing grub screws should be checked for tightness. Whilst the fans are running it is as well to confirm that the airflow has not been accidentally reversed at any time, and that there is no impeller out of balance.

Should this be the case remove the impeller, rotate through 180 deg. and replace - this may help; check also that the four mounting bolts at the motor body and the four at the condenser casing are secure.

### **EC fan specific information**

It is important that the EC fans are switched on and off via the control circuit and not by opening and closing the 3ph power. The EC fan contains a small processor that is powered from the main power supply. If the fan contactors are switched off the processor will show a power failure alarm. When the fans are restarted the processor needs to reload the control software and this will cause a slight delay in fan start up. With EC fans the 3ph power should be permanently on, and the fan rotation controlled using the 0-10v signal, 0v = fan stop.

The minimum fan run time should be 1hr per month. It is advised that should there be a high amount of standby time, i.e. the fans are mostly not running, that the fans should have at least 1 x 3hr solid run every 3 months to ensure the motor dries out and the bearings are lubricated.

### Fan Motor Removal

Remove fan guard and impeller by releasing the securing grub (screw(s) - red impellers have two, blue impellers only one) and withdrawing from shaft. The loop in the approach cable may be released from its cable tie to provide extra cable and the motor unbolted from the support arms - place hardboard beneath the motor to prevent the motor damaging the fins. The motor can be withdrawn and disconnected. It may be found easier to replace the motors by unbolting one of the two arms from the condenser casing, bolting the motor to the arms and finally the arm to the casing.

### EC Fan replacement

Each EC fan is held to the condenser casing structure with 4 x M12 bolts if the fan needs replacement the intention is that the entire fan assembly can be removed and replaced. If the motors are changed separately a range of Torx tools will be required, when the fixings are changed they require red lock-tight fluid to hold the thread

The power to the motor should be disconnected before any wires are disconnected from the motor terminal box.

All work carried on the fans and electrical connections needs to be undertaken by experienced engineers and if in any doubt over the procedure please contact Coolers and Condensers Ltd.

### Electrical Connections

Check wiring is secure and that terminal box remains waterproof, that fuses and overloads are intact and that motor current is correct.

### Wiring Diagram - (For single fan only - multiple Fans repeat).

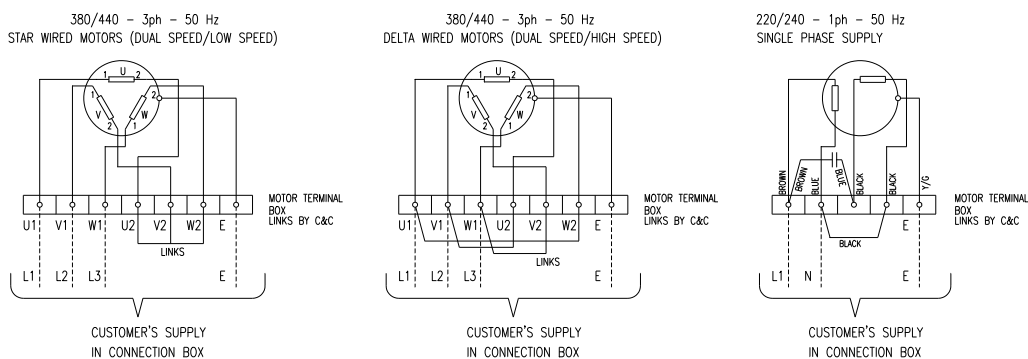

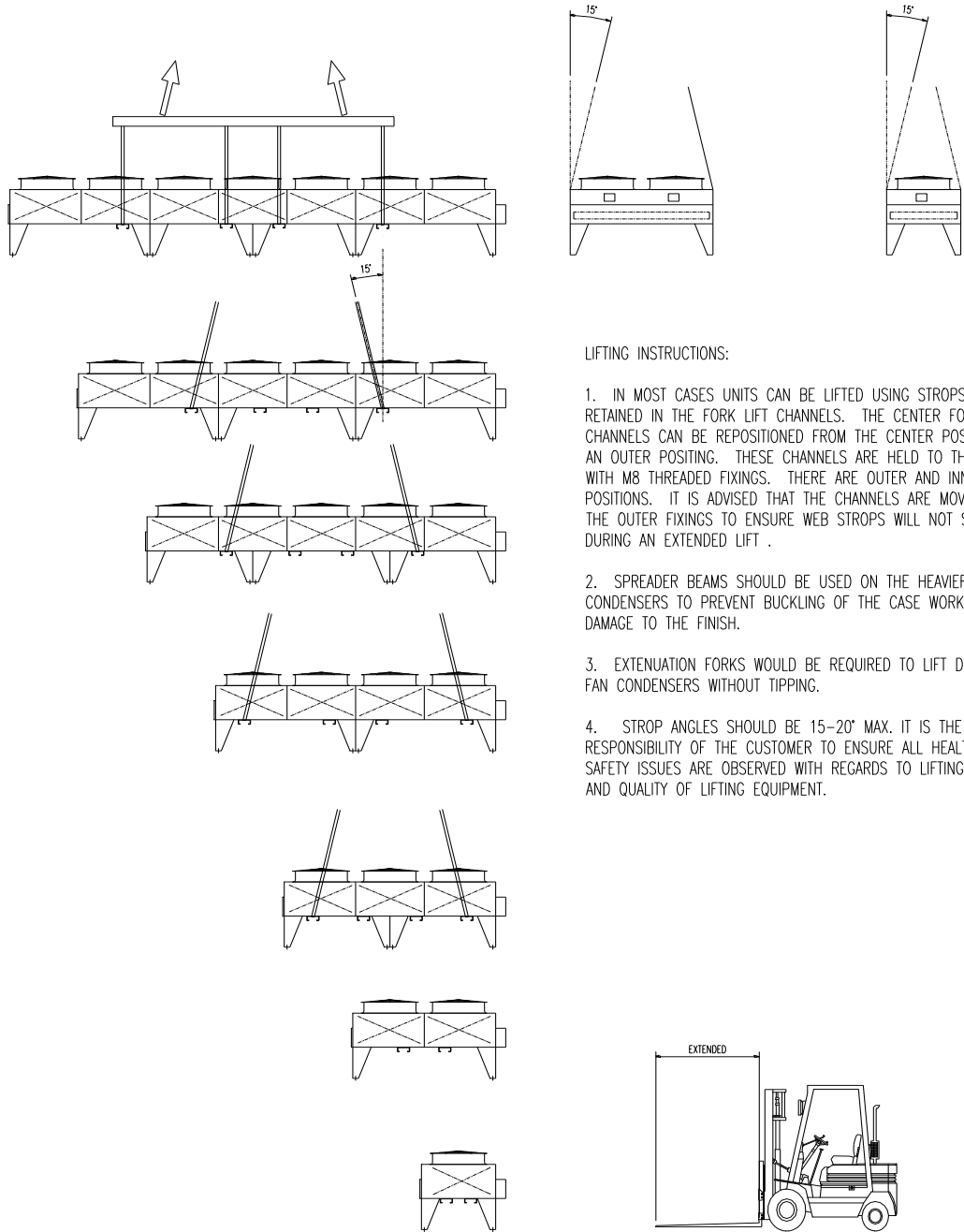

LIFTING INSTRUCTIONS:

1. IN MOST CASES UNITS CAN BE LIFTED USING STROPS RETAINED IN THE FORK LIFT CHANNELS. THE CENTER FORK LIFT CHANNELS CAN BE REPOSITIONED FROM THE CENTER POSITION TO AN OUTER POSITING. THESE CHANNELS ARE HELD TO THE UNIT WITH M8 THREADED FIXINGS. THERE ARE OUTER AND INNER POSITIONS. IT IS ADVISED THAT THE CHANNELS ARE MOVED TO THE OUTER FIXINGS TO ENSURE WEB STROPS WILL NOT SLIDE DURING AN EXTENDED LIFT .
2. SPREADER BEAMS SHOULD BE USED ON THE HEAVIER CONDENSERS TO PREVENT BUCKLING OF THE CASE WORK AND DAMAGE TO THE FINISH.
3. EXTENUATION FORKS WOULD BE REQUIRED TO LIFT DOUBLE FAN CONDENSERS WITHOUT TIPPING.
4. STROP ANGLES SHOULD BE 15-20° MAX. IT IS THE RESPONSIBILITY OF THE CUSTOMER TO ENSURE ALL HEALTH & SAFETY ISSUES ARE OBSERVED WITH REGARDS TO LIFTING METHOD AND QUALITY OF LIFTING EQUIPMENT.

**Coolers & Condensers Ltd**  
**12 Brunel Way**  
**Segensworth East Industrial Estate**  
**Fareham**  
**Hampshire**  
**UK**  
**PO15 5TX**

Tel : 0044 (1489) 885533  
 Fax : 0044 (1489) 885280  
 e-mail : [info@coolers.co.uk](mailto:info@coolers.co.uk)